

## 650 kHz/1.2 MHz, 18.5 V STEP-UP DC-DC CONVERTER WITH 3.2 A SWITCH

 Check for Samples: [TPS61087](#)

### FEATURES

- 2.5 V to 6 V Input Voltage Range
- 18.5 V Boost Converter With 3.2 A Switch Current
- 650 kHz/1.2 MHz Selectable Switching Frequency
- Adjustable Soft-Start
- Thermal Shutdown
- Undervoltage Lockout
- 10-Pin QFN and thin QFN Packages

### APPLICATIONS

- Handheld Devices
- GPS Receiver
- Digital Still Camera
- Portable Applications
- DSL Modem
- PCMCIA Card
- TFT LCD Bias Supply

### DESCRIPTION

The TPS61087 is a high frequency, high efficiency DC to DC converter with an integrated 3.2 A, 0.13  $\Omega$  power switch capable of providing an output voltage up to 18.5 V. The selectable frequency of 650 kHz or 1.2 MHz allows the use of small external inductors and capacitors and provides fast transient response. The external compensation allows optimizing the application for specific conditions. A capacitor connected to the soft-start pin minimizes inrush current at startup.

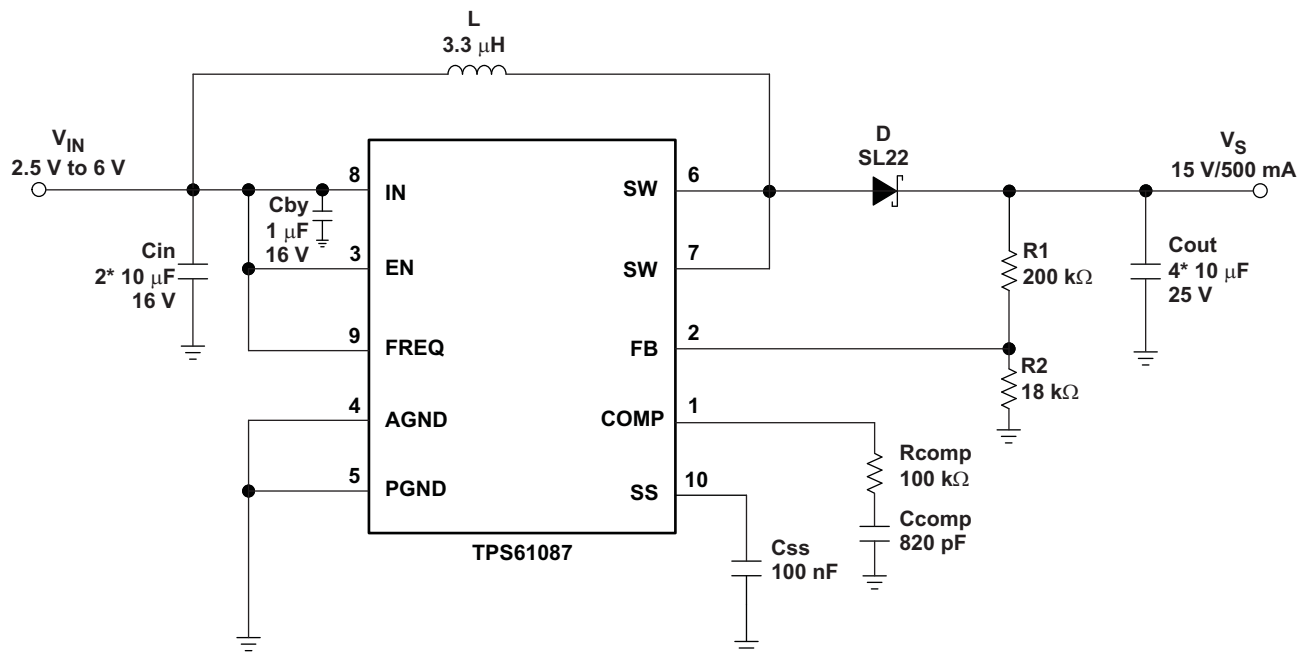

Please be aware that an important notice concerning availability, standard warranty, and use in critical applications of Texas Instruments semiconductor products and disclaimers thereto appears at the end of this data sheet.



These devices have limited built-in ESD protection. The leads should be shorted together or the device placed in conductive foam during storage or handling to prevent electrostatic damage to the MOS gates.

### ORDERING INFORMATION<sup>(1) (2)</sup>

T <sub>A</sub>	ORDERING	PACKAGE	PACKAGE MARKING
–40 to 85°C	TPS61087DRC	QFN-10 (DRC)	PMOQ
	TPS61087DSC	QFN-10 (DSC)	PMWI

- (1) The DRC package is available taped and reeled.  
 (2) For the most current package and ordering information, see the Package Option Addendum at the end of this document, or see the TI website at [www.ti.com](http://www.ti.com).

### ABSOLUTE MAXIMUM RATINGS

over operating free-air temperature range (unless otherwise noted)<sup>(1)</sup>

	VALUE	UNIT
Input voltage range I <sub>IN</sub> <sup>(2)</sup>	–0.3 to 7.0	V
Voltage range on pins EN, FB, SS, FREQ, COMP	–0.3 to 7.0	V
Voltage on pin SW	–0.3 to 20	V
ESD rating HBM	2	kV
ESD rating MM	200	V
ESD rating CDM	500	V
Continuous power dissipation	See Dissipation Rating Table	
Operating junction temperature range	–40 to 150	°C
Storage temperature range	–65 to 150	°C

- (1) Stresses beyond those listed under *absolute maximum ratings* may cause permanent damage to the device. These are stress ratings only, and functional operation of the device at these or any other conditions beyond those indicated under *recommended operating conditions* is not implied. Exposure to absolute-maximum-rated conditions for extended periods may affect device reliability.  
 (2) All voltage values are with respect to network ground terminal.

### DISSIPATION RATINGS<sup>(1) (2)</sup>

PACKAGE	T <sub>A</sub> ≤ 25°C POWER RATING	T <sub>A</sub> = 70°C POWER RATING	T <sub>A</sub> = 85°C POWER RATING
QFN	1.74 W	0.96 W	0.70 W

- (1)  $P_D = (T_J - T_A)/R_{\theta JA}$ .  
 (2) The exposed thermal die is soldered to the PCB using thermal vias. For more information, see the Texas Instruments Application report [SLMA002](#) regarding thermal characteristics of the PowerPAD package.

### RECOMMENDED OPERATING CONDITIONS

		MIN	TYP	MAX	UNIT
V <sub>IN</sub>	Input voltage range	2.5		6	V
V <sub>S</sub>	Boost output voltage range	V <sub>IN</sub> + 0.5		18.5	V
T <sub>A</sub>	Operating free-air temperature	–40		85	°C
T <sub>J</sub>	Operating junction temperature	–40		125	°C

**ELECTRICAL CHARACTERISTICS**
 $V_{IN} = 5\text{ V}$ ,  $EN = V_{IN}$ ,  $V_S = 15\text{ V}$ ,  $T_A = -40^\circ\text{C}$  to  $85^\circ\text{C}$ , typical values are at  $T_A = 25^\circ\text{C}$  (unless otherwise noted)

PARAMETER		TEST CONDITIONS	MIN	TYP	MAX	UNIT
<b>SUPPLY</b>						
$V_{IN}$	Input voltage range		2.5		6	V
$I_Q$	Operating quiescent current into IN	Device not switching, $V_{FB} = 1.3\text{ V}$		75	100	$\mu\text{A}$
$I_{SDVIN}$	Shutdown current into IN	$EN = \text{GND}$			1	$\mu\text{A}$
$V_{UVLO}$	Under-voltage lockout threshold	$V_{IN}$ falling			2.4	V
		$V_{IN}$ rising			2.5	V
$T_{SD}$	Thermal shutdown	Temperature rising		150		$^\circ\text{C}$
$T_{SDHYS}$	Thermal shutdown hysteresis			14		$^\circ\text{C}$
<b>LOGIC SIGNALS EN, FREQ</b>						
$V_{IH}$	High level input voltage	$V_{IN} = 2.5\text{ V}$ to $6.0\text{ V}$	2			V
$V_{IL}$	Low level input voltage	$V_{IN} = 2.5\text{ V}$ to $6.0\text{ V}$			0.5	V
$I_{INLEAK}$	Input leakage current	$EN = \text{FREQ} = \text{GND}$			0.1	$\mu\text{A}$
<b>BOOST CONVERTER</b>						
$V_S$	Boost output voltage		$V_{IN} + 0.5$		18.5	V
$V_{FB}$	Feedback regulation voltage		1.230	1.238	1.246	V
gm	Transconductance error amplifier			107		$\mu\text{A/V}$
$I_{FB}$	Feedback input bias current	$V_{FB} = 1.238\text{ V}$			0.1	$\mu\text{A}$
$r_{DS(on)}$	N-channel MOSFET on-resistance	$V_{IN} = V_{GS} = 5\text{ V}$ , $I_{SW} = \text{current limit}$		0.13	0.18	$\Omega$
		$V_{IN} = V_{GS} = 3\text{ V}$ , $I_{SW} = \text{current limit}$		0.16	0.23	
$I_{SWLEAK}$	SW leakage current	$EN = \text{GND}$ , $V_{SW} = V_{IN} = 6.0\text{ V}$			2	$\mu\text{A}$
$I_{LIM}$	N-Channel MOSFET current limit		3.2	4.0	4.8	A
$I_{SS}$	Soft-start current	$V_{SS} = 1.238\text{ V}$	7	10	13	$\mu\text{A}$
$f_S$	Oscillator frequency	$\text{FREQ} = V_{IN}$	0.9	1.2	1.5	MHz
		$\text{FREQ} = \text{GND}$	480	650	820	kHz
	Line regulation	$V_{IN} = 2.5\text{ V}$ to $6.0\text{ V}$ , $I_{OUT} = 10\text{ mA}$		0.0002		%/V
	Load regulation	$V_{IN} = 5.0\text{ V}$ , $I_{OUT} = 1\text{ mA}$ to $1\text{ A}$		0.11		%/A

**PIN ASSIGNMENT**

**DRC, DSC PACKAGE  
(TOP VIEW)**

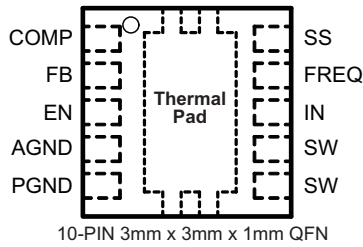

**PIN FUNCTIONS**

PIN		I/O	DESCRIPTION
NAME	NO.		
COMP	1	I/O	Compensation pin
FB	2	I	Feedback pin
EN	3	I	Shutdown control input. Connect this pin to logic high level to enable the device
AGND	4, Thermal Pad		Analog ground
PGND	5		Power ground
SW	6, 7		Switch pin
IN	8		Input supply pin
FREQ	9	I	Frequency select pin. The power switch operates at 650 kHz if FREQ is connected to GND and at 1.2 MHz if FREQ is connected to IN
SS	10		Soft-start control pin. Connect a capacitor to this pin if soft-start needed. Open = no soft-start

**TYPICAL CHARACTERISTICS**

**TABLE OF GRAPHS**

			FIGURE
$I_{OUT(max)}$	Maximum load current	vs. Input voltage at High frequency (1.2 MHz)	Figure 1
$I_{OUT(max)}$	Maximum load current	vs. Input voltage at Low frequency (650 kHz)	Figure 2
$\eta$	Efficiency	vs. Load current, $V_S = 15\text{ V}$ , $V_{IN} = 5\text{ V}$	Figure 3
$\eta$	Efficiency	vs. Load current, $V_S = 9\text{ V}$ , $V_{IN} = 3.3\text{ V}$	Figure 4
	PWM switching - discontinuous conduction		Figure 5
	PWM switching - continuous conduction		Figure 6
	Load transient response	at High frequency (1.2 MHz)	Figure 7
	Load transient response	at Low frequency (650 kHz)	Figure 8
	Soft-start		Figure 9
	Supply current	vs. Supply voltage	Figure 10
	Oscillator frequency	vs. Load current	Figure 11
	Oscillator frequency	vs. Supply voltage	Figure 12

The typical characteristics are measured with the inductors 7447789003 3.3  $\mu\text{H}$  (high frequency) or 74454068 6.8  $\mu\text{H}$  (low frequency) from Wurth and the rectifier diode SL22.

TYPICAL CHARACTERISTICS (continued)

MAXIMUM LOAD CURRENT  
VS  
INPUT VOLTAGE

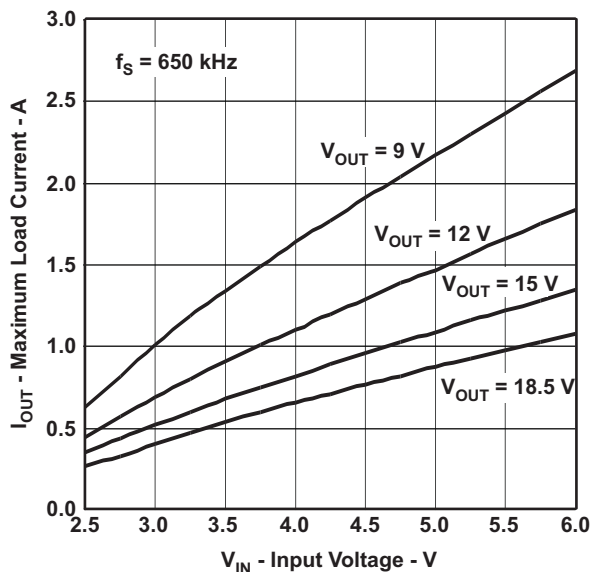

Figure 1.

MAXIMUM LOAD CURRENT  
VS  
INPUT VOLTAGE

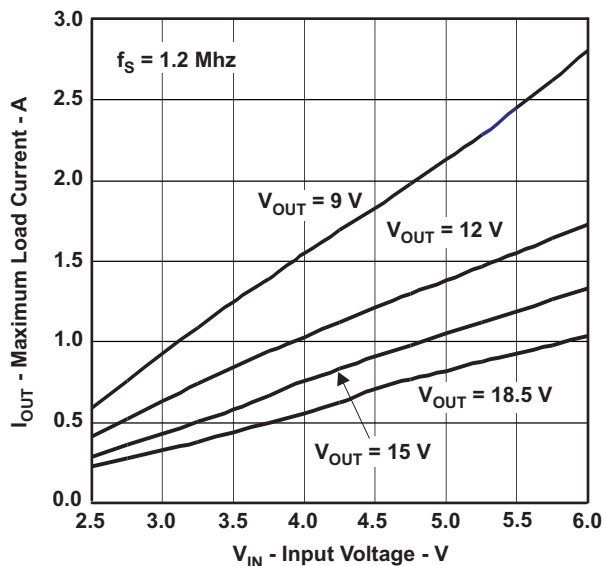

Figure 2.

EFFICIENCY  
VS  
LOAD CURRENT

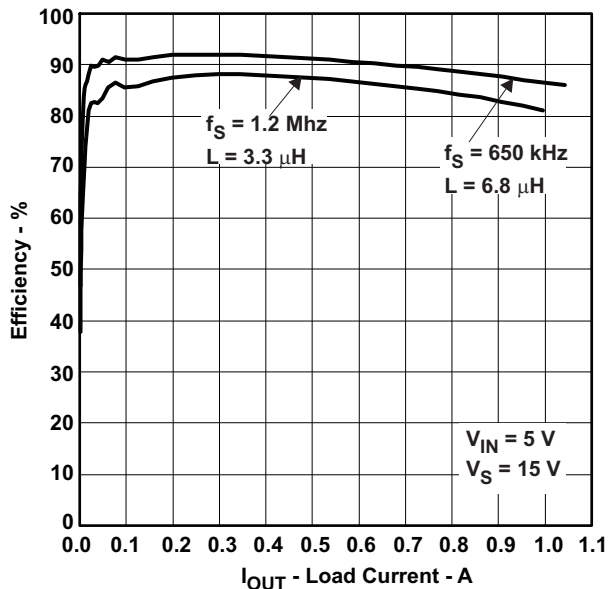

Figure 3.

EFFICIENCY  
VS  
LOAD CURRENT

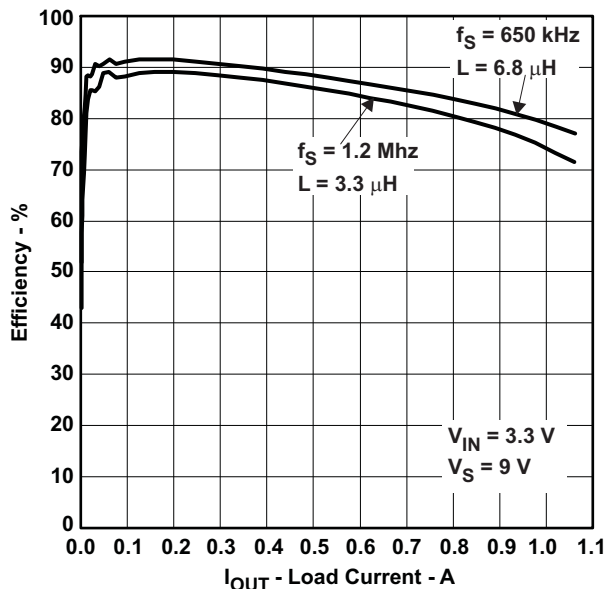

Figure 4.

TYPICAL CHARACTERISTICS (continued)

PWM SWITCHING  
DISCONTINUOUS CONDUCTION MODE

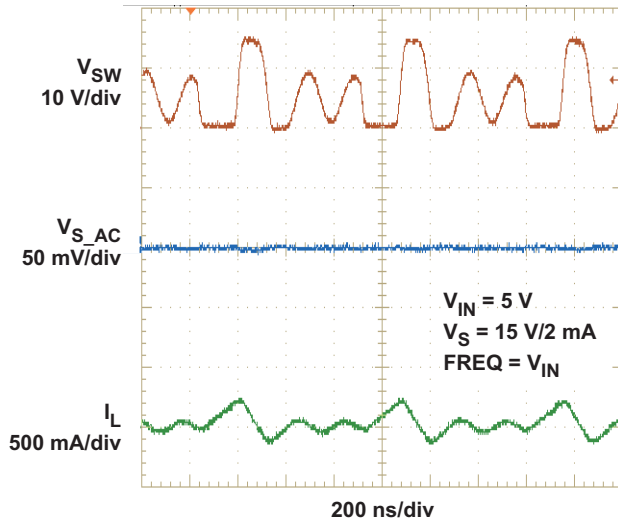

Figure 5.

PWM SWITCHING  
CONTINUOUS CONDUCTION MODE

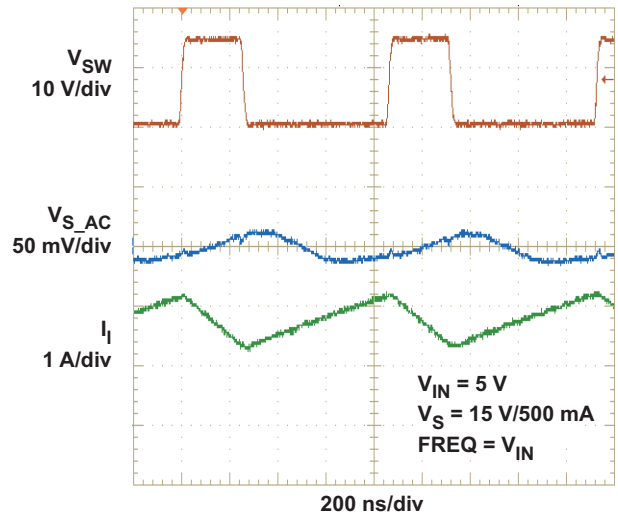

Figure 6.

LOAD TRANSIENT RESPONSE  
HIGH FREQUENCY (1.2 MHz)

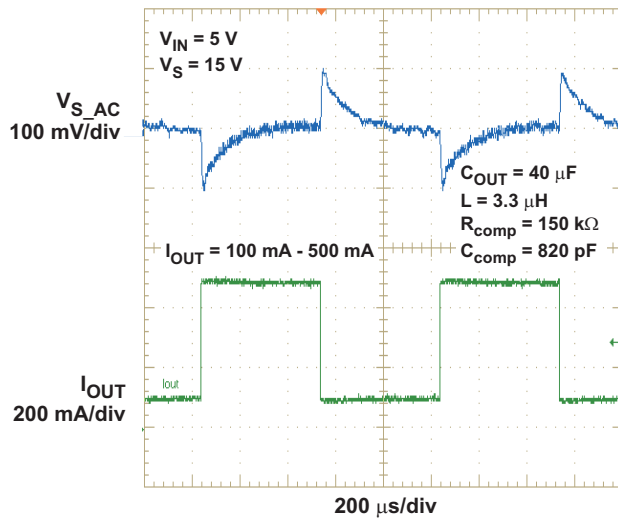

Figure 7.

LOAD TRANSIENT RESPONSE  
LOW FREQUENCY (650 kHz)

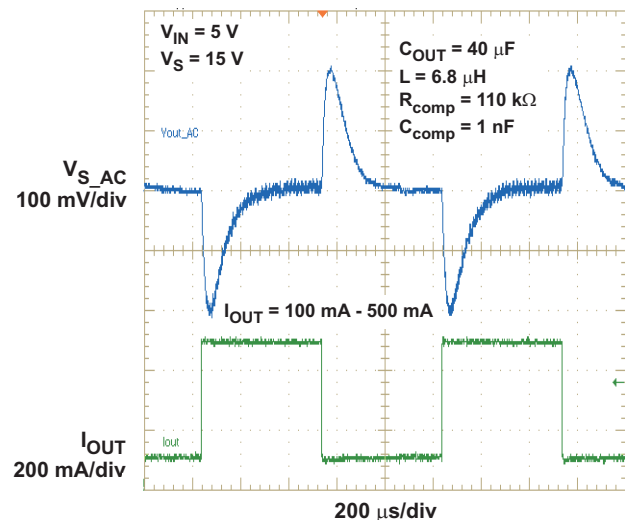

Figure 8.

TYPICAL CHARACTERISTICS (continued)

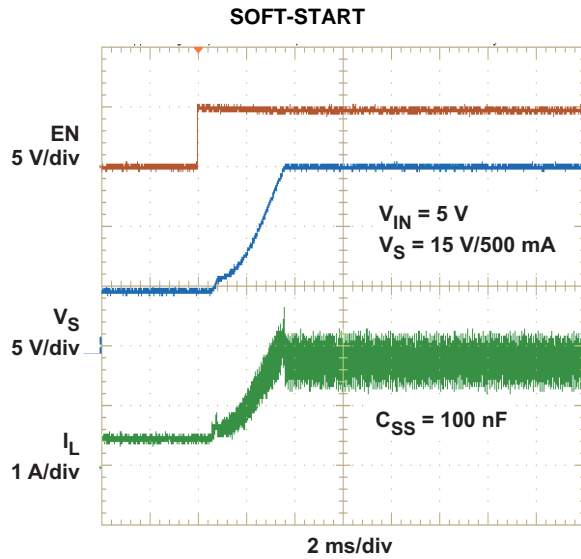

Figure 9.

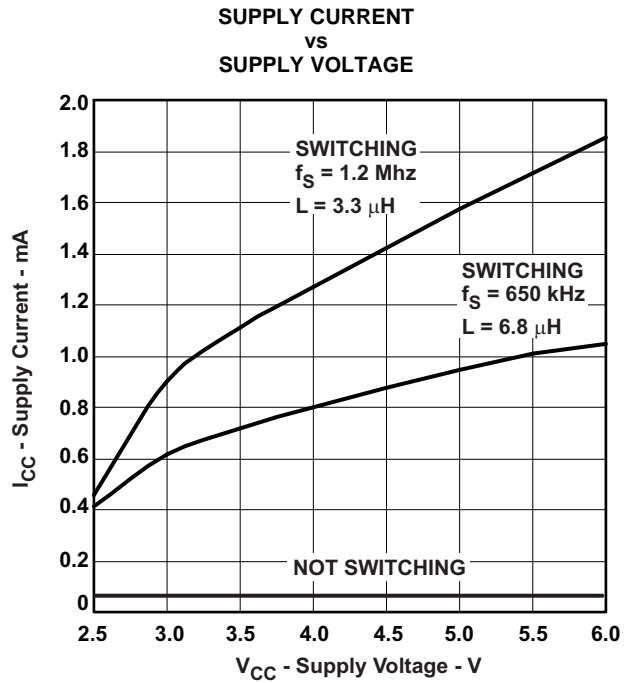

Figure 10.

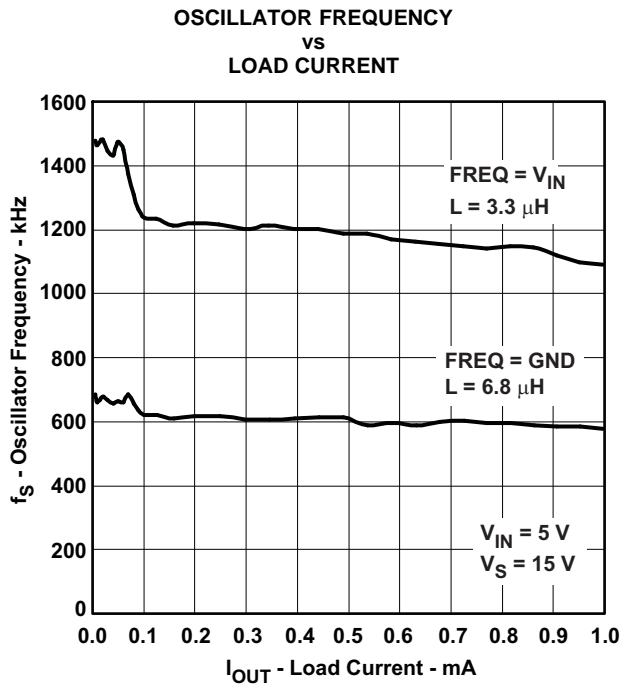

Figure 11.

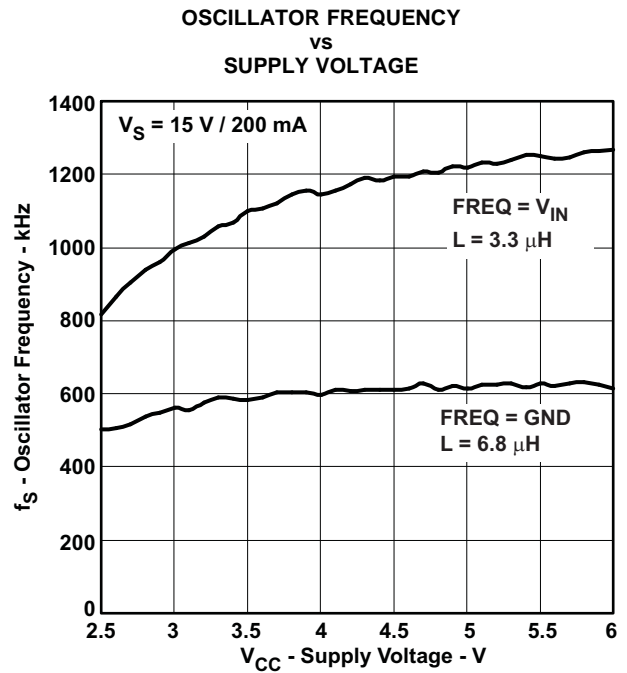

Figure 12.

DETAILED DESCRIPTION

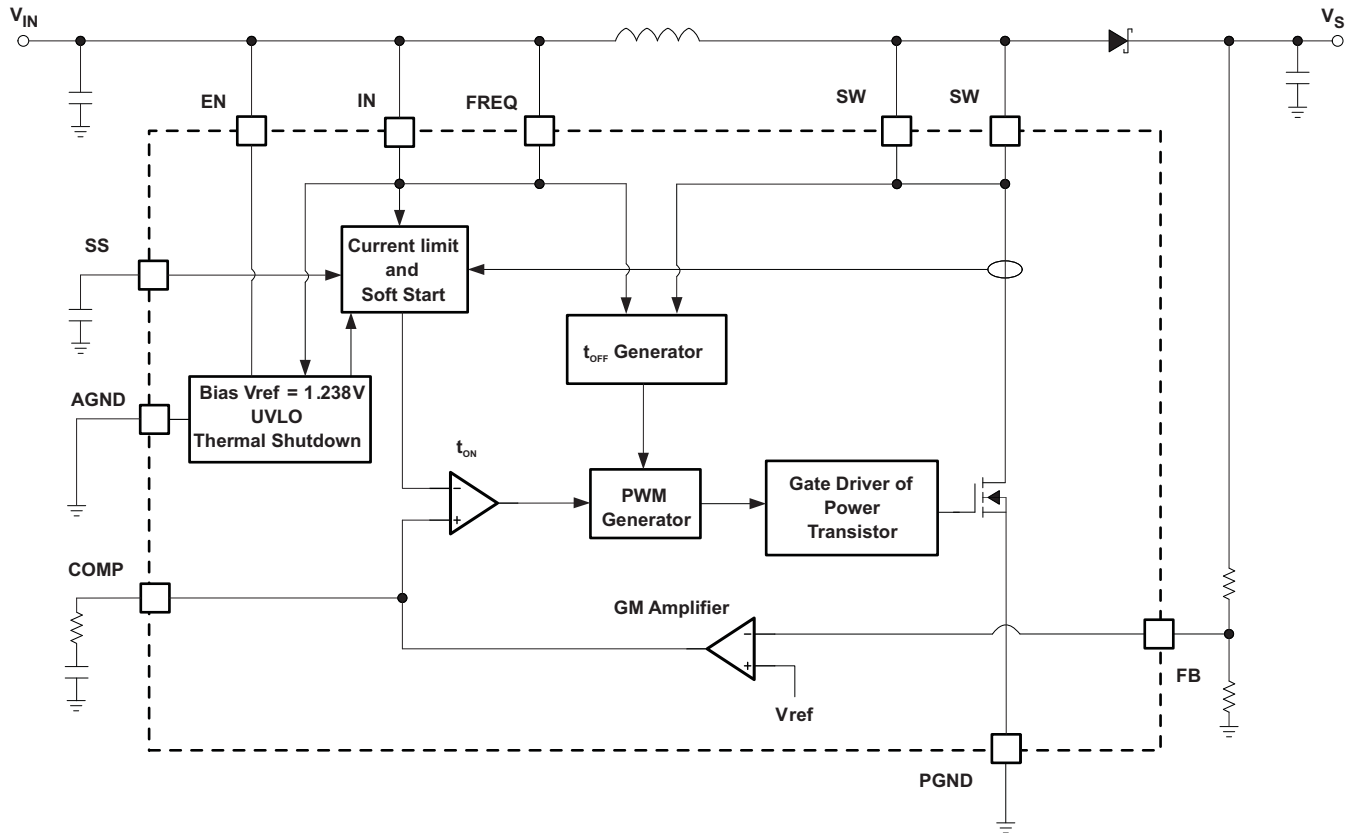

Figure 13. Block Diagram

The boost converter is designed for output voltages up to 18.5 V with a switch peak current limit of 3.2 A minimum. The device, which operates in a current mode scheme with quasi-constant frequency, is externally compensated for maximum flexibility and stability. The switching frequency is selectable between 650 kHz and 1.2 MHz and the minimum input voltage is 2.5 V. To limit the inrush current at start-up a soft-start pin is available.

TPS61087 boost converter’s novel topology using adaptive off-time provides superior load and line transient responses and operates also over a wider range of applications than conventional converters.

The selectable switching frequency offers the possibility to optimize the design either for the use of small sized components (1.2 MHz) or for higher system efficiency (650 kHz). However, the frequency changes slightly because the voltage drop across the  $r_{DS(on)}$  has some influence on the current and voltage measurement and thus on the on-time (the off-time remains constant).

The converter operates in continuous conduction mode (CCM) as soon as the input current increases above half the ripple current in the inductor, for lower load currents it switches into discontinuous conduction mode (DCM). If the load is further reduced, the part starts to skip pulses to maintain the output voltage.

## Design Procedure

The first step in the design procedure is to verify that the maximum possible output current of the boost converter supports the specific application requirements. A simple approach is to estimate the converter efficiency, by taking the efficiency numbers from the provided efficiency curves or to use a worst case assumption for the expected efficiency, e.g. 90%.

1. Duty cycle,  $D$ :

$$D = 1 - \frac{V_{IN} \cdot \eta}{V_S} \quad (1)$$

2. Maximum output current,  $I_{out(max)}$ :

$$I_{out(max)} = \left( I_{LIM(min)} - \frac{\Delta I_L}{2} \right) \cdot (1 - D) \quad (2)$$

3. Peak switch current in application,  $I_{swpeak}$ :

$$I_{swpeak} = \frac{\Delta I_L}{2} + \frac{I_{out}}{1 - D} \quad (3)$$

with the inductor peak-to-peak ripple current,  $\Delta I_L$

$$\Delta I_L = \frac{V_{IN} \cdot D}{f_S \cdot L} \quad (4)$$

and

$V_{IN}$	Minimum input voltage
$V_S$	Output voltage
$I_{LIM(min)}$	Converter switch current limit (minimum switch current limit = 3.2 A)
$f_S$	Converter switching frequency (typically 1.2 MHz or 650 kHz)
$L$	Selected inductor value
$\eta$	Estimated converter efficiency (please use the number from the efficiency plots or 90% as an estimation)

The peak switch current is the steady state peak switch current that the integrated switch, inductor and external Schottky diode has to be able to handle. The calculation must be done for the minimum input voltage where the peak switch current is the highest.

## Soft-start

The boost converter has an adjustable soft-start to prevent high inrush current during start-up. To minimize the inrush current during start-up an external capacitor, connected to the soft-start pin SS and charged with a constant current, is used to slowly ramp up the internal current limit of the boost converter. When the EN pin is pulled high, the soft-start capacitor  $C_{SS}$  is immediately charged to 0.3 V. The capacitor is then charged at a constant current of 10  $\mu$ A typically until the output of the boost converter  $V_S$  has reached its Power Good threshold (roughly 98% of  $V_S$  nominal value). During this time, the SS voltage directly controls the peak inductor current, starting with 0 A at  $V_{SS} = 0.3$  V up to the full current limit at  $V_{SS} = 800$  mV. The maximum load current is available after the soft-start is completed. The larger the capacitor the slower the ramp of the current limit and the longer the soft-start time. A 100 nF capacitor is usually sufficient for most of the applications. When the EN pin is pulled low, the soft-start capacitor is discharged to ground.

**Inductor Selection**

The TPS61087 is designed to work with a wide range of inductors. The main parameter for the inductor selection is the saturation current of the inductor which should be higher than the peak switch current as calculated in the *Design Procedure* section with additional margin to cover for heavy load transients. An alternative, more conservative, is to choose an inductor with a saturation current at least as high as the maximum switch current limit of 4.8 A. The other important parameter is the inductor DC resistance. Usually the lower the DC resistance the higher the efficiency. It is important to note that the inductor DC resistance is not the only parameter determining the efficiency. Especially for a boost converter where the inductor is the energy storage element, the type and core material of the inductor influences the efficiency as well. At high switching frequencies of 1.2 MHz inductor core losses, proximity effects and skin effects become more important. Usually an inductor with a larger form factor gives higher efficiency. The efficiency difference between different inductors can vary between 2% to 10%. For the TPS61087, inductor values between 3 μH and 6 μH are a good choice with a switching frequency of 1.2 MHz, typically 3.3 μH. At 650 kHz we recommend inductors between 6 μH and 13 μH, typically 6.8 μH. Possible inductors are shown in [Table 1](#).

Typically, it is recommended that the inductor current ripple is below 35% of the average inductor current. Therefore, the following equation can be used to calculate the inductor value, L:

$$L = \left( \frac{V_{IN}}{V_S} \right)^2 \cdot \left( \frac{V_S - V_{IN}}{I_{out} \cdot f_S} \right) \cdot \left( \frac{\eta}{0.35} \right) \tag{5}$$

with

- $V_{IN}$  Minimum input voltage
- $V_S$  Output voltage
- $I_{out}$  Maximum output current in the application
- $f_S$  Converter switching frequency (typically 1.2 MHz or 650 kHz)
- $\eta$  Estimated converter efficiency (please use the number from the efficiency plots or 90% as an estimation)

**Table 1. Inductor Selection**

L (μH)	SUPPLIER	COMPONENT CODE	SIZE (L×W×H mm)	DCR TYP (mΩ)	I <sub>sat</sub> (A)
<b>1.2 MHz</b>					
4.2	Sumida	CDRH5D28	5.7 × 5.7 × 3	23	2.2
4.7	Würth Elektronik	7447785004	5.9 × 6.2 × 3.3	60	2.5
5	Coilcraft	MSS7341	7.3 × 7.3 × 4.1	24	2.9
5	Sumida	CDRH6D28	7 × 7 × 3	23	2.4
4.6	Sumida	CDR7D28	7.6 × 7.6 × 3	38	3.15
4.7	Würth Elektronik	7447789004	7.3 × 7.3 × 3.2	33	3.9
3.3	Würth Elektronik	7447789003	7.3 × 7.3 × 3.2	30	4.2
<b>650 kHz</b>					
10	Würth Elektronik	744778910	7.3 × 7.3 × 3.2	51	2.2
10	Sumida	CDRH8D28	8.3 × 8.3 × 3	36	2.7
6.8	Sumida	CDRH6D26HPNP	7 × 7 × 2.8	52	2.9
6.2	Sumida	CDRH8D58	8.3 × 8.3 × 6	25	3.3
10	Coilcraft	DS3316P	12.95 × 9.40 × 5.08	80	3.5
10	Sumida	CDRH8D43	8.3 × 8.3 × 4.5	29	4
6.8	Würth Elektronik	74454068	12.7 × 10 × 4.9	55	4.1

## Rectifier Diode Selection

To achieve high efficiency a Schottky type should be used for the rectifier diode. The reverse voltage rating should be higher than the maximum output voltage of the converter. The averaged rectified forward current  $I_{avg}$ , the Schottky diode needs to be rated for, is equal to the output current  $I_{out}$ :

$$I_{avg} = I_{out} \quad (6)$$

Usually a Schottky diode with 2 A maximum average rectified forward current rating is sufficient for most applications. The Schottky rectifier can be selected with lower forward current capability depending on the output current  $I_{out}$  but has to be able to dissipate the power. The dissipated power,  $P_D$ , is the average rectified forward current times the diode forward voltage,  $V_{forward}$ .

$$P_D = I_{avg} \cdot V_{forward} \quad (7)$$

Typically the diode should be able to dissipate around 500mW depending on the load current and forward voltage.

**Table 2. Rectifier Diode Selection**

CURRENT RATING $I_{avg}$	$V_r$	$V_{forward}/I_{avg}$	SUPPLIER	COMPONENT CODE
2 A	20 V	0.44 V / 2 A	Vishay Semiconductor	SL22
2 A	20 V	0.5 V / 2 A	Fairchild Semiconductor	SS22

## Setting the Output Voltage

The output voltage is set by an external resistor divider. Typically, a minimum current of 50  $\mu$ A flowing through the feedback divider gives good accuracy and noise covering. A standard low side resistor of 18 k $\Omega$  is typically selected. The resistors are then calculated as:

$$R2 = \frac{V_{FB}}{70\mu A} \approx 18k\Omega \quad R1 = R2 \cdot \left( \frac{V_s}{V_{FB}} - 1 \right)$$

$$V_{FB} = 1.238V$$

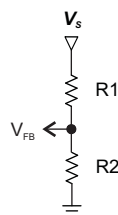

(8)

## Compensation (COMP)

The regulator loop can be compensated by adjusting the external components connected to the COMP pin. The COMP pin is the output of the internal transconductance error amplifier.

Standard values of  $R_{COMP} = 16$  k $\Omega$  and  $C_{COMP} = 2.7$  nF will work for the majority of the applications.

See [Table 3](#) for dedicated compensation networks giving an improved load transient response. The following equations can be used to calculate  $R_{COMP}$  and  $C_{COMP}$ :

$$R_{COMP} = \frac{110 \cdot V_{IN} \cdot V_s \cdot C_{out}}{L \cdot I_{out}} \quad C_{COMP} = \frac{V_s \cdot C_{out}}{7.5 \cdot I_{out} \cdot R_{COMP}} \quad (9)$$

with

$V_{IN}$	Minimum input voltage
$V_s$	Output voltage
$C_{out}$	Output capacitance
$L$	Inductor value, e.g. 3.3 $\mu$ H or 6.8 $\mu$ H
$I_{out}$	Maximum output current in the application

Make sure that  $R_{COMP} < 120$  k $\Omega$  and  $C_{COMP} > 820$  pF, independent of the results of the above formulas.

**Table 3. Recommended Compensation Network Values at High/Low Frequency**

FREQUENCY	L	V <sub>S</sub>	V <sub>IN</sub> ± 20%	R <sub>COMP</sub>	C <sub>COMP</sub>
High (1.2 MHz)	3.3 μH	15 V	5 V	100 kΩ	820 pF
			3.3 V	91 kΩ	1.2 nF
		12 V	5 V	68 kΩ	820 pF
			3.3 V	68 kΩ	1.2 nF
		9 V	5 V	39 kΩ	820 pF
			3.3 V	39 kΩ	1.2 nF
Low (650 kHz)	6.8 μH	15 V	5 V	51 kΩ	1.5 nF
			3.3 V	47 kΩ	2.7 nF
		12 V	5 V	33 kΩ	1.5 nF
			3.3 V	33 kΩ	2.7 nF
		9 V	5 V	18 kΩ	1.5 nF
			3.3 V	18 kΩ	2.7 nF

Table 3 gives conservative  $R_{COMP}$  and  $C_{COMP}$  values for certain inductors, input and output voltages providing a very stable system. For a faster response time, a higher  $R_{COMP}$  value can be used to enlarge the bandwidth, as well as a slightly lower value of  $C_{COMP}$  to keep enough phase margin. These adjustments should be performed in parallel with the load transient response monitoring of TPS61087.

### Input Capacitor Selection

For good input voltage filtering low ESR ceramic capacitors are recommended. TPS61087 has an analog input IN. Therefore, a 1 μF bypass is highly recommended as close as possible to the IC from IN to GND.

Two 10 μF (or one 22 μF) ceramic input capacitors are sufficient for most of the applications. For better input voltage filtering this value can be increased. See Table 4 and typical applications for input capacitor recommendation.

### Output Capacitor Selection

For best output voltage filtering a low ESR output capacitor like ceramic capacitor is recommended. Four 10 μF ceramic output capacitors (or two 22 μF) work for most of the applications. Higher capacitor values can be used to improve the load transient response. See Table 4 for the selection of the output capacitor.

**Table 4. Rectifier Input and Output Capacitor Selection**

	CAPACITOR/SIZE	VOLTAGE RATING	SUPPLIER	COMPONENT CODE
C <sub>IN</sub>	22 μF/1206	16 V	Taiyo Yuden	EMK316 BJ 226ML
IN bypass	1 μF/0603	16 V	Taiyo Yuden	EMK107 BJ 105KA
C <sub>OUT</sub>	10 μF/1206	25 V	Taiyo Yuden	TMK316 BJ 106KL

To calculate the output voltage ripple, the following equation can be used:

$$\Delta V_C = \frac{V_S - V_{IN}}{V_S} \cdot \frac{I_{out}}{f_S \cdot C_{out}} \quad \Delta V_{C\_ESR} = I_{L(peak)} \cdot R_{C\_ESR} \quad (10)$$

with

$\Delta V_C$	Output voltage ripple dependent on output capacitance, output current and switching frequency
$V_S$	Output voltage
$V_{IN}$	Minimum input voltage of boost converter
$f_S$	Converter switching frequency (typically 1.2 MHz or 650 kHz)
$I_{out}$	Output current
$\Delta V_{C\_ESR}$	Output voltage ripple due to output capacitors ESR (equivalent series resistance)
$I_{SWPEAK}$	Inductor peak switch current in the application

$R_{C\_ESR}$  Output capacitors equivalent series resistance (ESR)

$\Delta V_{C\_ESR}$  can be neglected in many cases since ceramic capacitors provide low ESR.

### Frequency Select Pin (FREQ)

The frequency select pin FREQ allows to set the switching frequency of the device to 650 kHz (FREQ = low) or 1.2 MHz (FREQ = high). Higher switching frequency improves load transient response but reduces slightly the efficiency. The other benefits of higher switching frequency are a lower output ripple voltage. The use of a 1.2 MHz switching frequency is recommended unless light load efficiency is a major concern.

### Undervoltage Lockout (UVLO)

To avoid mis-operation of the device at low input voltages an undervoltage lockout is included that disables the device, if the input voltage falls below 2.4 V.

### Thermal Shutdown

A thermal shutdown is implemented to prevent damages due to excessive heat and power dissipation. Typically the thermal shutdown happens at a junction temperature of 150°C. When the thermal shutdown is triggered the device stops switching until the junction temperature falls below typically 136°C. Then the device starts switching again.

### Overvoltage Prevention

If overvoltage is detected on the FB pin (typically 3 % above the nominal value of 1.238 V) the part stops switching immediately until the voltage on this pin drops to its nominal value. This prevents overvoltage on the output and secures the circuits connected to the output from excessive overvoltage.

APPLICATION INFORMATION

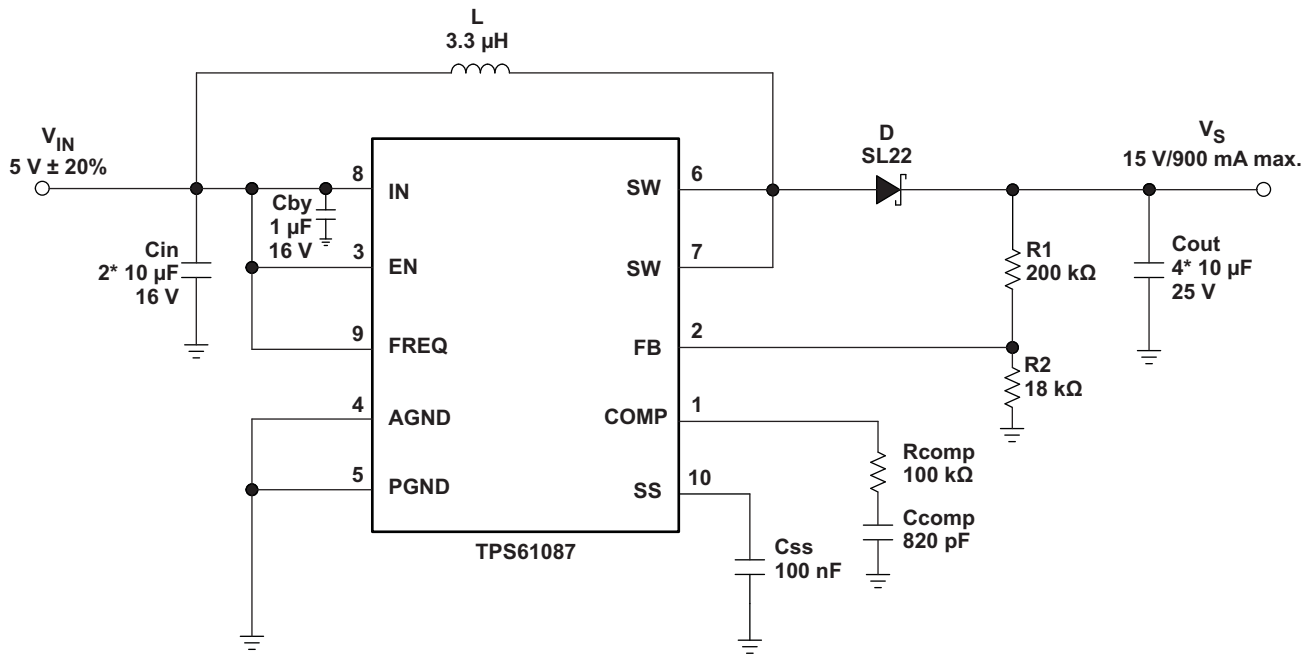

Figure 14. Typical Application, 5 V to 15 V ( $f_s = 1.2$  MHz)

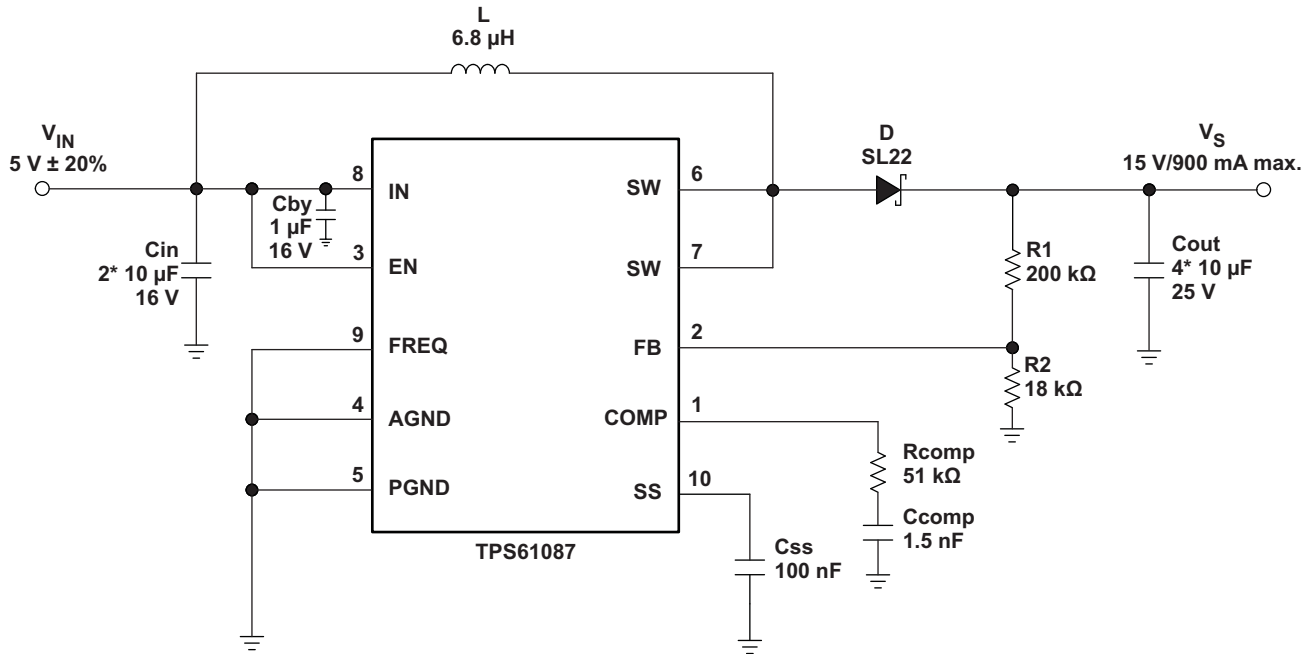

Figure 15. Typical Application, 5 V to 15 V ( $f_s = 650$  kHz)

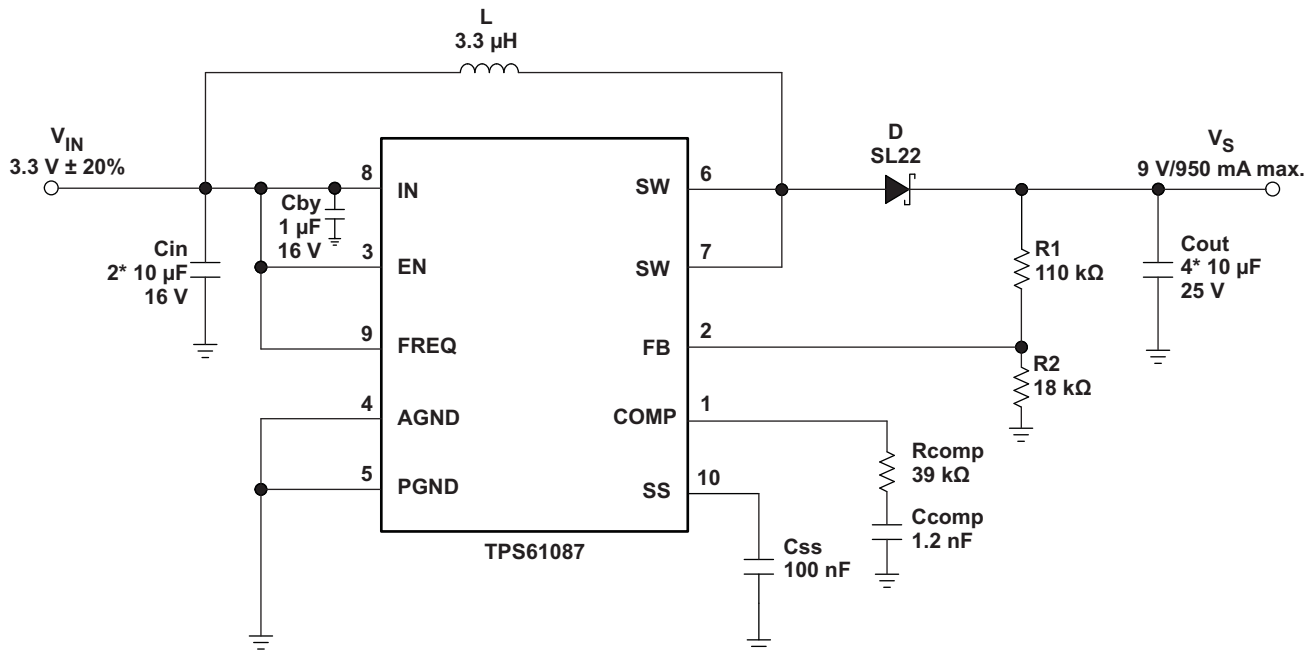

Figure 16. Typical Application, 3.3 V to 9 V ( $f_s = 1.2\text{ MHz}$ )

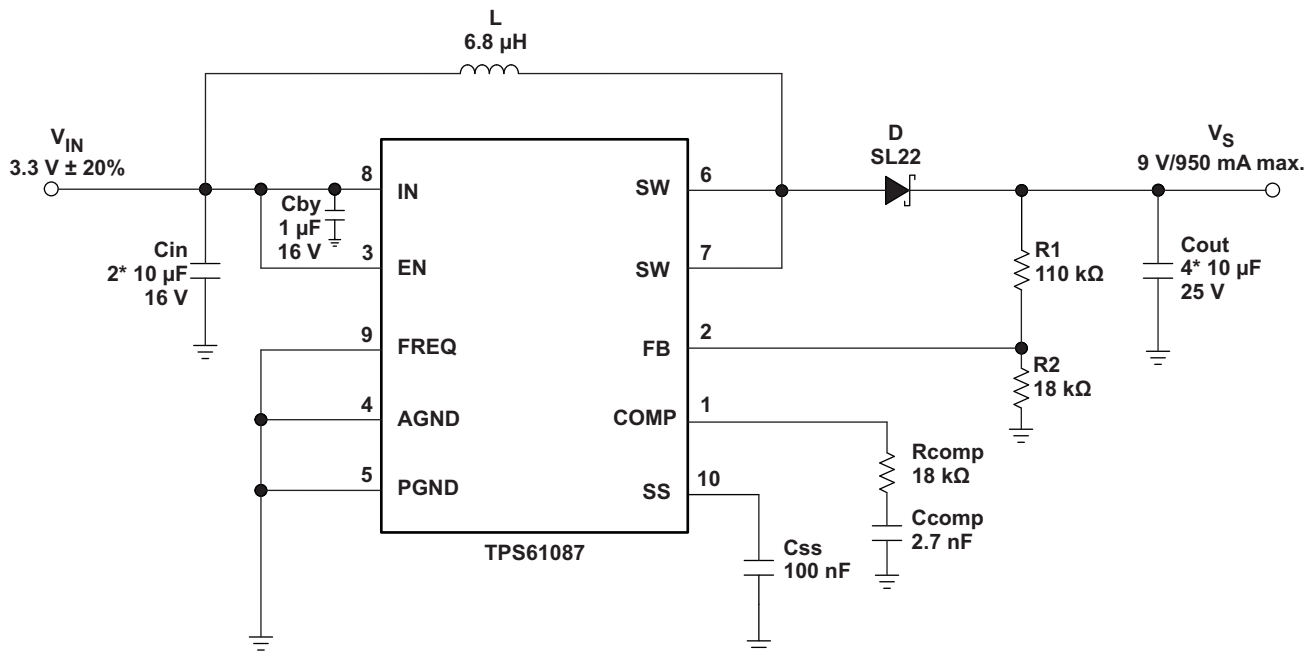

Figure 17. Typical Application, 3.3 V to 9 V ( $f_s = 650\text{ kHz}$ )

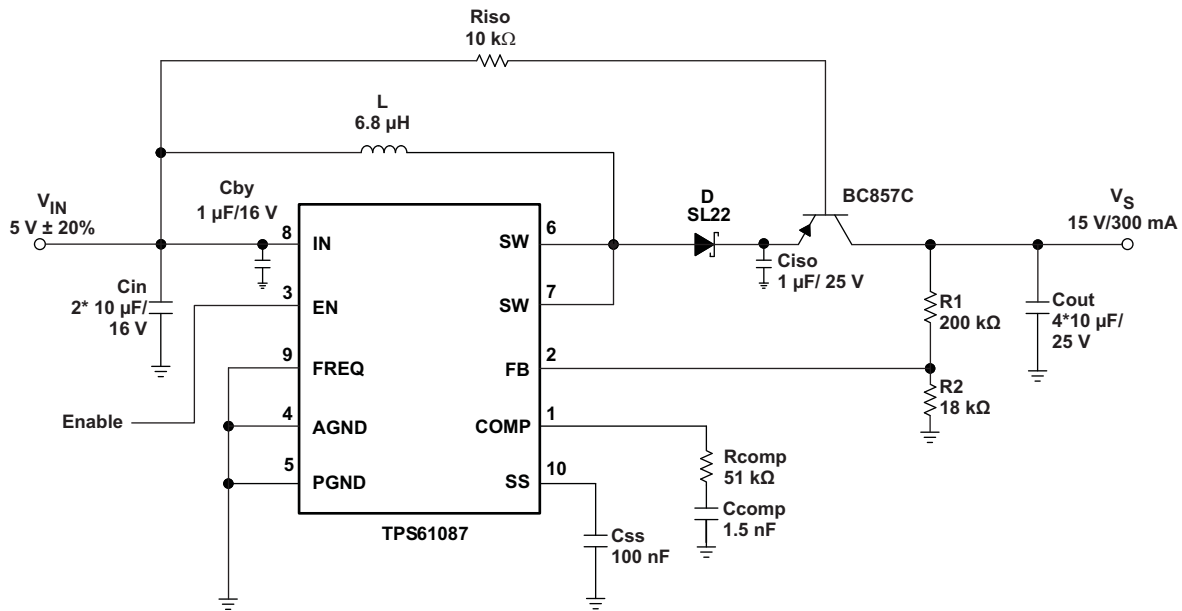

Figure 18. Typical Application with External Load Disconnect Switch

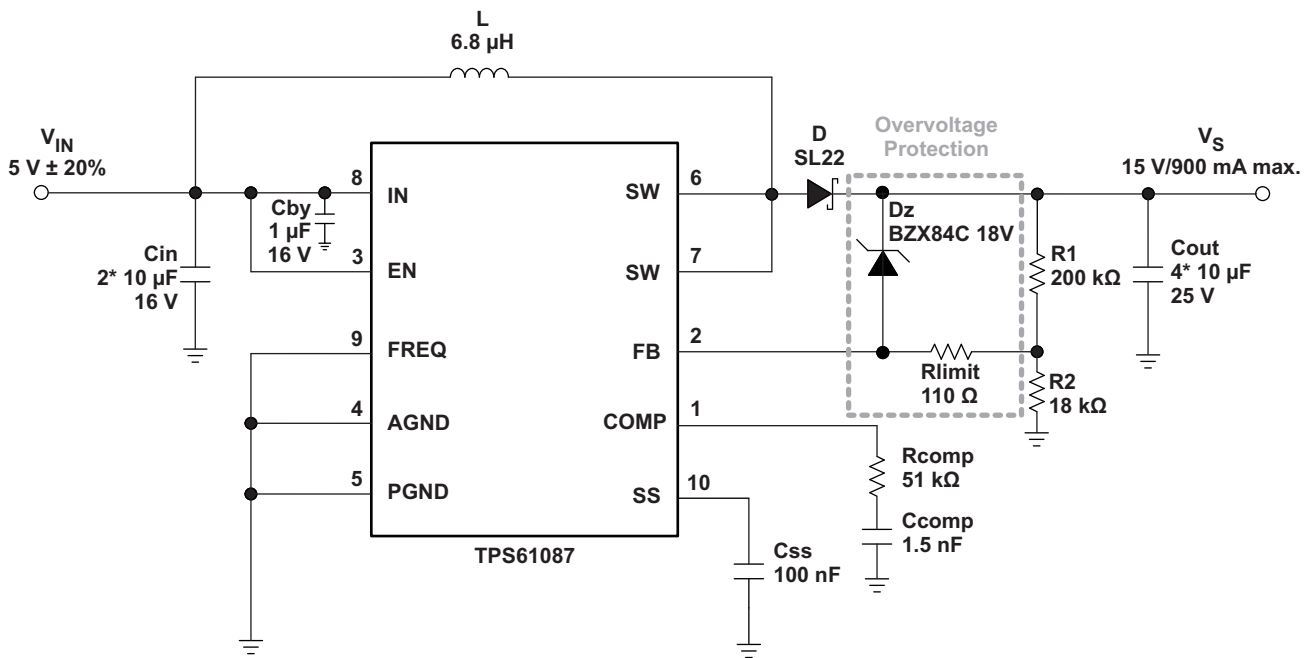

Figure 19. Typical Application, 5 V to 15 V ( $f_s = 1.2$  MHz) with Overvoltage Protection

TFT LCD APPLICATION

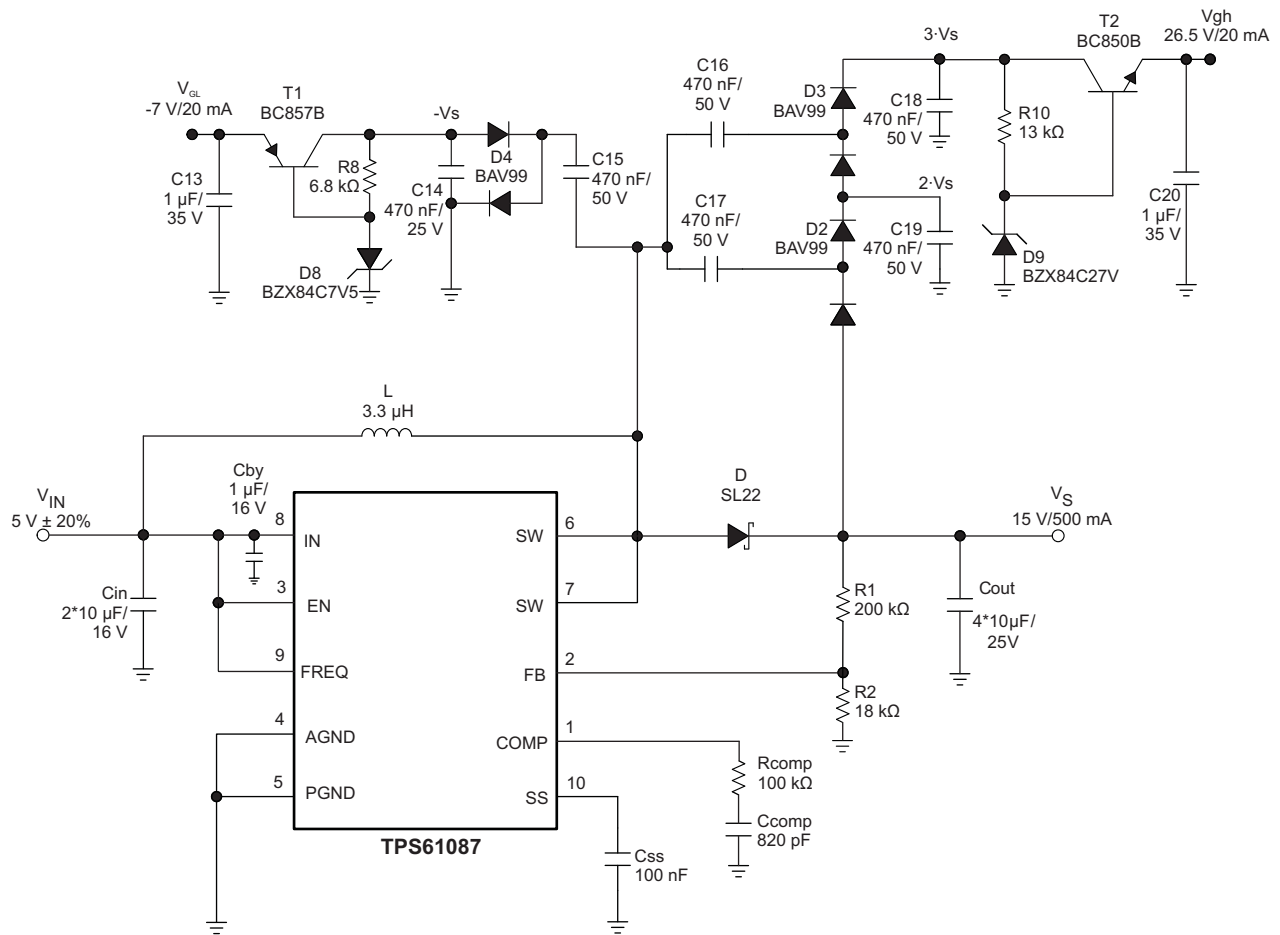

Figure 20. Typical Application 5 V to 15 V ( $f_s = 1.2$  MHz) for TFT LCD with External Charge Pumps (VGH, VGL)

WHITE LED APPLICATIONS

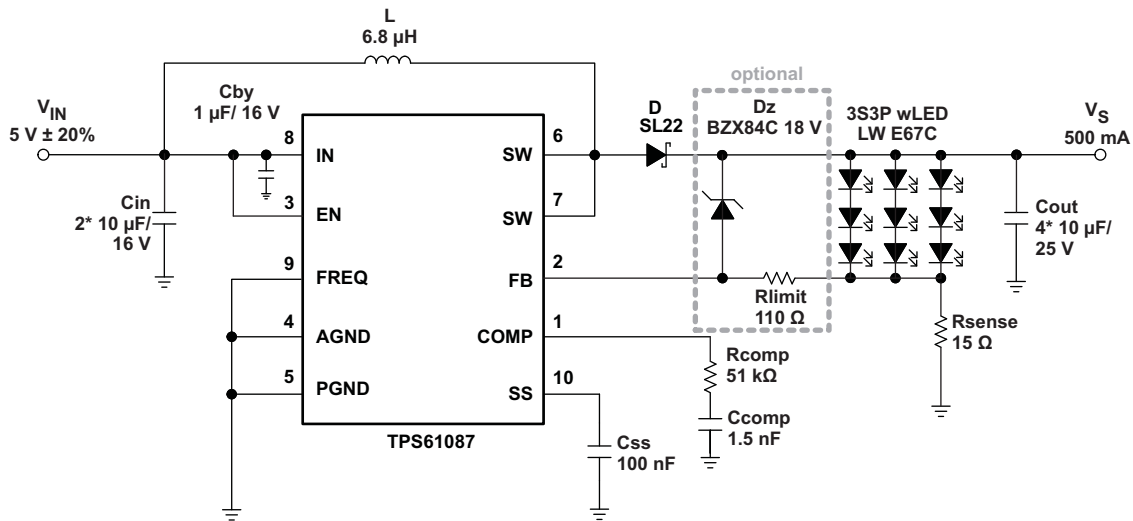

Figure 21. Simple Application (5 V input voltage) ( $f_s = 650$  kHz) for wLED Supply (3S3P) (with optional clamping Zener diode)

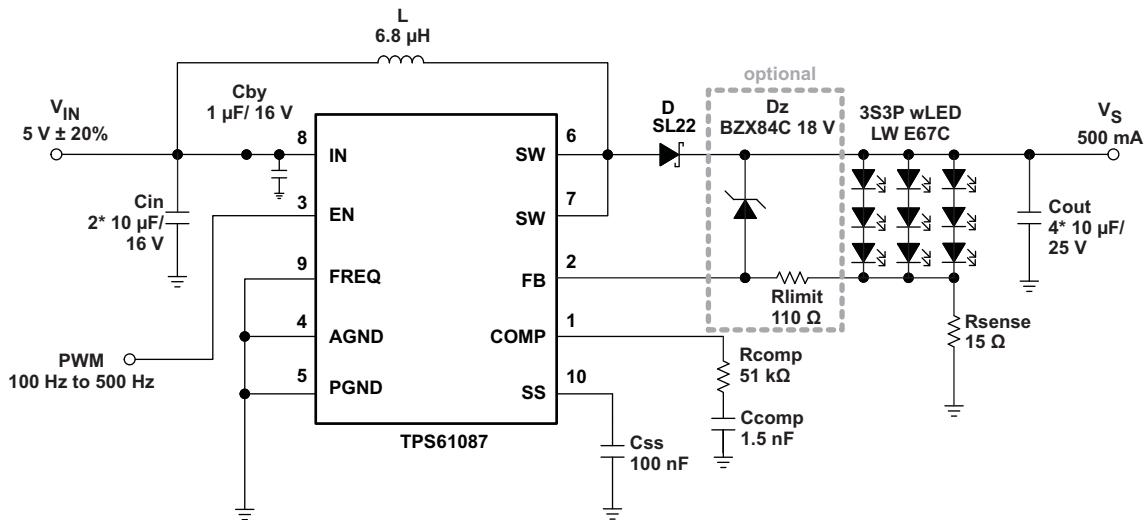

Figure 22. Simple Application (5 V input voltage) ( $f_s = 650$  kHz) for wLED Supply (3S3P) with Adjustable Brightness Control using a PWM Signal on the Enable Pin (with optional clamping Zener diode)

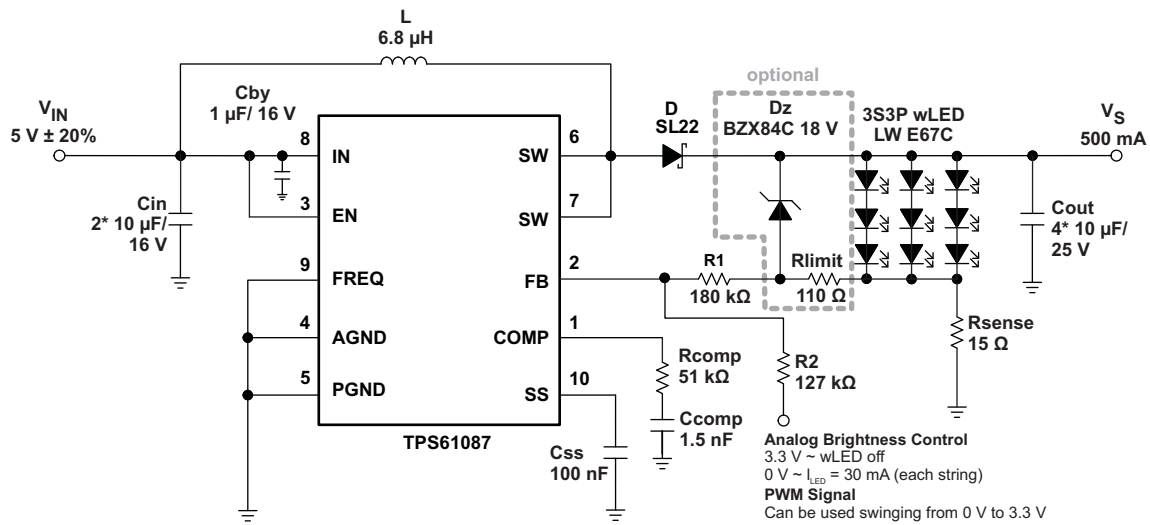

Figure 23. Simple Application (5 V input voltage) ( $f_s = 650$  kHz) for wLED Supply (3S3P) with Adjustable Brightness Control using an Analog Signal on the Feedback Pin (with optional clamping Zener diode)

## REVISION HISTORY

### Changes from Original (May 2008) to Revision A

Page

- Added three paragraphs of text to the Detailed Description - following the Block Diagram ..... 8

### Changes from Revision A (June 2008) to Revision B

Page

- Added DSC device to top of front page ..... 1
- Changed the Description to read From: The selectable frequency of 650 kHz and 1.2 MHz... To: The selectable frequency of 650 kHz or 1.2 MHz ..... 1
- Added DSC package to ORDERING INFORMATION ..... 2
- Deleted Lead temperature from Absolute Maximum Ratings ..... 2
- Changed Voltage on pin SW from 20 V to –0.3 to 20 V in Absolute Maximum Ratings ..... 2
- Deleted  $R_{\theta JA}$  from DISSIPATION RATINGS ..... 2
- Changed  $f_{osc}$  to  $f_s$  in Electrical Characteristics Boost Converter Oscillator Frequency ..... 3
- Changed  $FREQ = high$  to  $FREQ = V_{IN}$  in Electrical Characteristics Boost Converter Oscillator Frequency ..... 3
- Changed  $FREQ = low$  to  $FREQ = GND$  in Electrical Characteristics Boost Converter Oscillator Frequency ..... 3
- Added DSC package to PIN ASSIGNMENT ..... 4
- Added Maximum load current vs. Input voltage graph ..... 4
- Added Maximum load current vs. Input voltage graph ..... 4
- Changed  $f$  to  $f_s$  and Frequency to Oscillator Frequency in [Figure 11](#) ..... 7
- Changed  $f$  to  $f_s$  and Frequency to Oscillator Frequency in [Figure 12](#) ..... 7
- Changed the text to the Detailed Description - reduced the numer of paragraphs from four to two. .... 8
- Changed the Design Procudures step 3 details - to make formulas easier to understand ..... 9
- Changed Inductor Selection text From: Typically, it is recommended that the inductor current ripple is below 20% To: Typically, it is recommended that the inductor current ripple is below 35% ..... 10
- Changed the format of [Table 3](#) ..... 12
- Changed wording in Compensation description ..... 12
- Added detailed information following [Table 4](#) - to make formulas easier to understand ..... 12
- Changed wording in Thermal Shutdown section ..... 13

**PACKAGING INFORMATION**

Orderable Device	Status <sup>(1)</sup>	Package Type	Package Drawing	Pins	Package Qty	Eco Plan <sup>(2)</sup>	Lead/Ball Finish	MSL Peak Temp <sup>(3)</sup>
TPS61087DRCR	ACTIVE	SON	DRC	10	3000	Green (RoHS & no Sb/Br)	CU NIPDAU	Level-2-260C-1 YEAR
TPS61087DRCRG4	ACTIVE	SON	DRC	10	3000	Green (RoHS & no Sb/Br)	CU NIPDAU	Level-2-260C-1 YEAR
TPS61087DRCT	ACTIVE	SON	DRC	10	250	Green (RoHS & no Sb/Br)	CU NIPDAU	Level-2-260C-1 YEAR
TPS61087DRCTG4	ACTIVE	SON	DRC	10	250	Green (RoHS & no Sb/Br)	CU NIPDAU	Level-2-260C-1 YEAR
TPS61087DSCR	ACTIVE	SON	DSC	10	3000	Green (RoHS & no Sb/Br)	CU NIPDAU	Level-2-260C-1 YEAR
TPS61087DSCT	ACTIVE	SON	DSC	10	250	Green (RoHS & no Sb/Br)	CU NIPDAU	Level-2-260C-1 YEAR

<sup>(1)</sup> The marketing status values are defined as follows:

**ACTIVE:** Product device recommended for new designs.

**LIFEBUY:** TI has announced that the device will be discontinued, and a lifetime-buy period is in effect.

**NRND:** Not recommended for new designs. Device is in production to support existing customers, but TI does not recommend using this part in a new design.

**PREVIEW:** Device has been announced but is not in production. Samples may or may not be available.

**OBSOLETE:** TI has discontinued the production of the device.

<sup>(2)</sup> Eco Plan - The planned eco-friendly classification: Pb-Free (RoHS), Pb-Free (RoHS Exempt), or Green (RoHS & no Sb/Br) - please check <http://www.ti.com/productcontent> for the latest availability information and additional product content details.

**TBD:** The Pb-Free/Green conversion plan has not been defined.

**Pb-Free (RoHS):** TI's terms "Lead-Free" or "Pb-Free" mean semiconductor products that are compatible with the current RoHS requirements for all 6 substances, including the requirement that lead not exceed 0.1% by weight in homogeneous materials. Where designed to be soldered at high temperatures, TI Pb-Free products are suitable for use in specified lead-free processes.

**Pb-Free (RoHS Exempt):** This component has a RoHS exemption for either 1) lead-based flip-chip solder bumps used between the die and package, or 2) lead-based die adhesive used between the die and leadframe. The component is otherwise considered Pb-Free (RoHS compatible) as defined above.

**Green (RoHS & no Sb/Br):** TI defines "Green" to mean Pb-Free (RoHS compatible), and free of Bromine (Br) and Antimony (Sb) based flame retardants (Br or Sb do not exceed 0.1% by weight in homogeneous material)

<sup>(3)</sup> MSL, Peak Temp. -- The Moisture Sensitivity Level rating according to the JEDEC industry standard classifications, and peak solder temperature.

**Important Information and Disclaimer:** The information provided on this page represents TI's knowledge and belief as of the date that it is provided. TI bases its knowledge and belief on information provided by third parties, and makes no representation or warranty as to the accuracy of such information. Efforts are underway to better integrate information from third parties. TI has taken and continues to take reasonable steps to provide representative and accurate information but may not have conducted destructive testing or chemical analysis on incoming materials and chemicals. TI and TI suppliers consider certain information to be proprietary, and thus CAS numbers and other limited information may not be available for release.

In no event shall TI's liability arising out of such information exceed the total purchase price of the TI part(s) at issue in this document sold by TI to Customer on an annual basis.

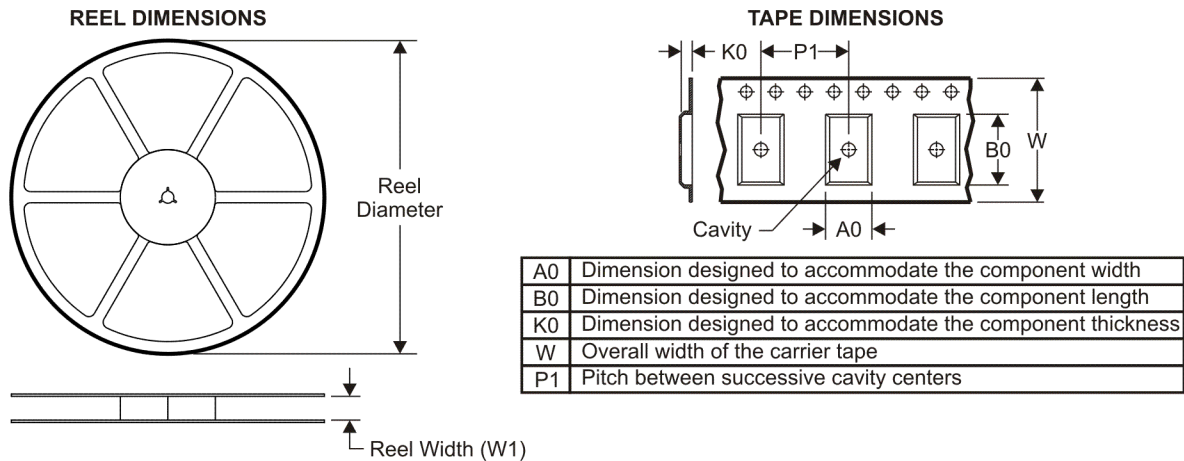
**TAPE AND REEL INFORMATION**

**QUADRANT ASSIGNMENTS FOR PIN 1 ORIENTATION IN TAPE**

\*All dimensions are nominal

Device	Package Type	Package Drawing	Pins	SPQ	Reel Diameter (mm)	Reel Width W1 (mm)	A0 (mm)	B0 (mm)	K0 (mm)	P1 (mm)	W (mm)	Pin1 Quadrant
TPS61087DRCR	SON	DRC	10	3000	330.0	12.4	3.3	3.3	1.1	8.0	12.0	Q2
TPS61087DRCR	SON	DRC	10	3000	330.0	12.4	3.3	3.3	1.1	8.0	12.0	Q2
TPS61087DRCT	SON	DRC	10	250	180.0	12.4	3.3	3.3	1.1	8.0	12.0	Q2
TPS61087DRCT	SON	DRC	10	250	180.0	12.4	3.3	3.3	1.1	8.0	12.0	Q2
TPS61087DSCR	SON	DSC	10	3000	330.0	12.4	3.3	3.3	1.1	8.0	12.0	Q2
TPS61087DSCT	SON	DSC	10	250	180.0	12.4	3.3	3.3	1.1	8.0	12.0	Q2

**TAPE AND REEL BOX DIMENSIONS**

\*All dimensions are nominal

Device	Package Type	Package Drawing	Pins	SPQ	Length (mm)	Width (mm)	Height (mm)
TPS61087DRCR	SON	DRC	10	3000	346.0	346.0	29.0
TPS61087DRCR	SON	DRC	10	3000	346.0	346.0	29.0
TPS61087DRCT	SON	DRC	10	250	190.5	212.7	31.8
TPS61087DRCT	SON	DRC	10	250	190.5	212.7	31.8
TPS61087DSCR	SON	DSC	10	3000	346.0	346.0	29.0
TPS61087DSCT	SON	DSC	10	250	190.5	212.7	31.8

DRC (S-PVSON-N10)

PLASTIC SMALL OUTLINE NO-LEAD

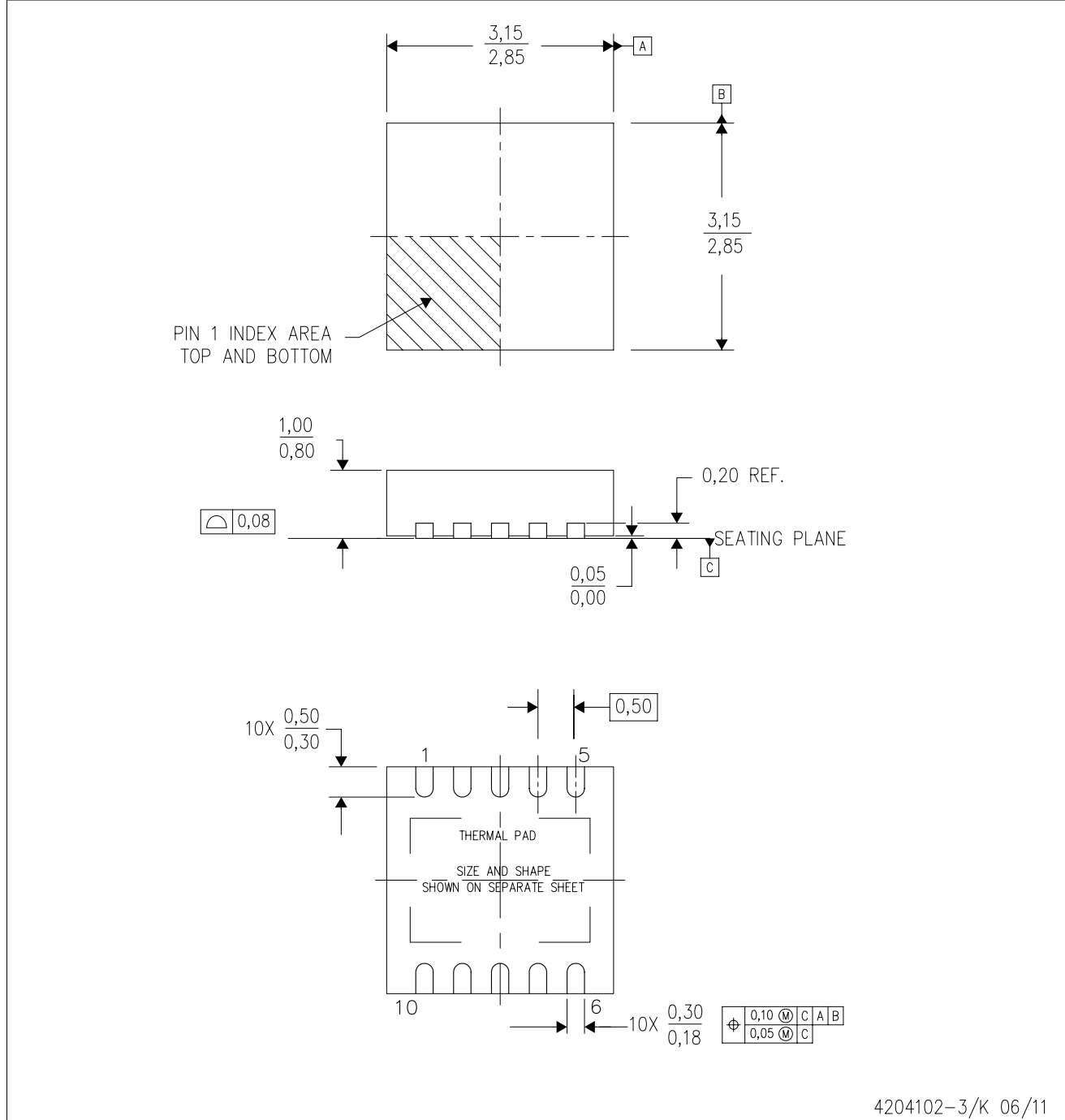

- NOTES:
- All linear dimensions are in millimeters. Dimensioning and tolerancing per ASME Y14.5M-1994.
  - This drawing is subject to change without notice.
  - Small Outline No-Lead (SON) package configuration.
  - The package thermal pad must be soldered to the board for thermal and mechanical performance.
  - See the additional figure in the Product Data Sheet for details regarding the exposed thermal pad features and dimensions.

# THERMAL PAD MECHANICAL DATA

DRC (S-PVSON-N10)

PLASTIC SMALL OUTLINE NO-LEAD

## THERMAL INFORMATION

This package incorporates an exposed thermal pad that is designed to be attached directly to an external heatsink. The thermal pad must be soldered directly to the printed circuit board (PCB). After soldering, the PCB can be used as a heatsink. In addition, through the use of thermal vias, the thermal pad can be attached directly to the appropriate copper plane shown in the electrical schematic for the device, or alternatively, can be attached to a special heatsink structure designed into the PCB. This design optimizes the heat transfer from the integrated circuit (IC).

For information on the Quad Flatpack No-Lead (QFN) package and its advantages, refer to Application Report, QFN/SON PCB Attachment, Texas Instruments Literature No. SLUA271. This document is available at [www.ti.com](http://www.ti.com).

The exposed thermal pad dimensions for this package are shown in the following illustration.

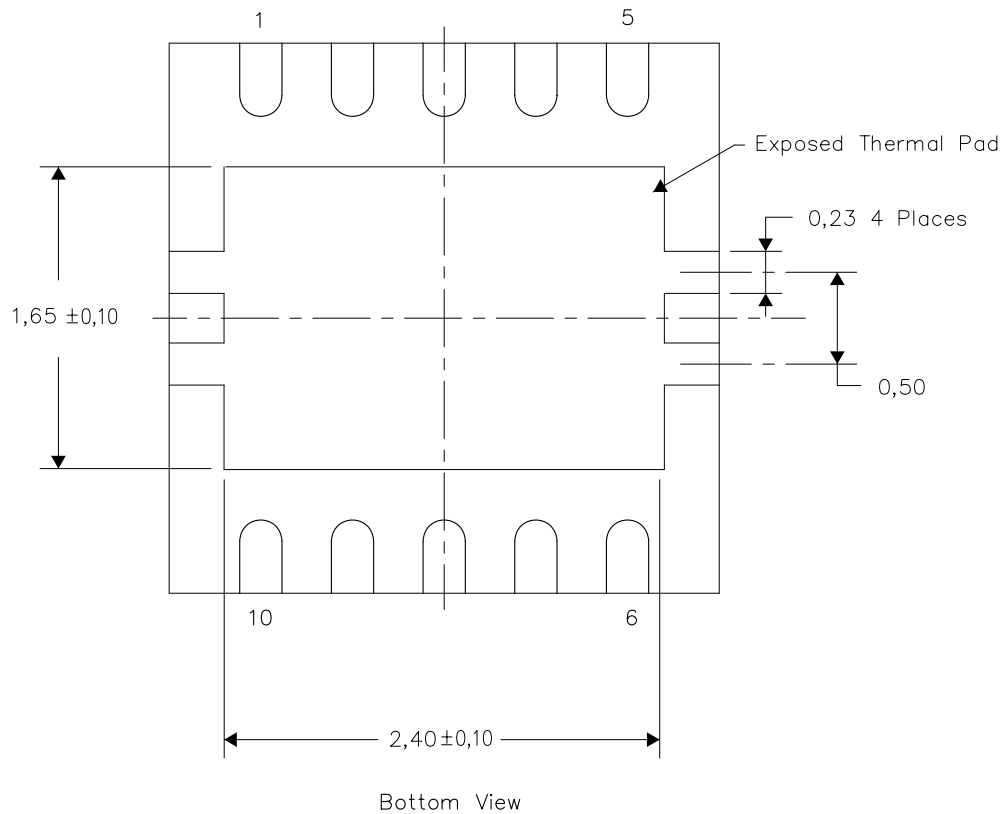

Exposed Thermal Pad Dimensions

4206565-3/M 06/11

NOTE: A. All linear dimensions are in millimeters

DRC (S-PVSON-N10)

PLASTIC SMALL OUTLINE NO-LEAD

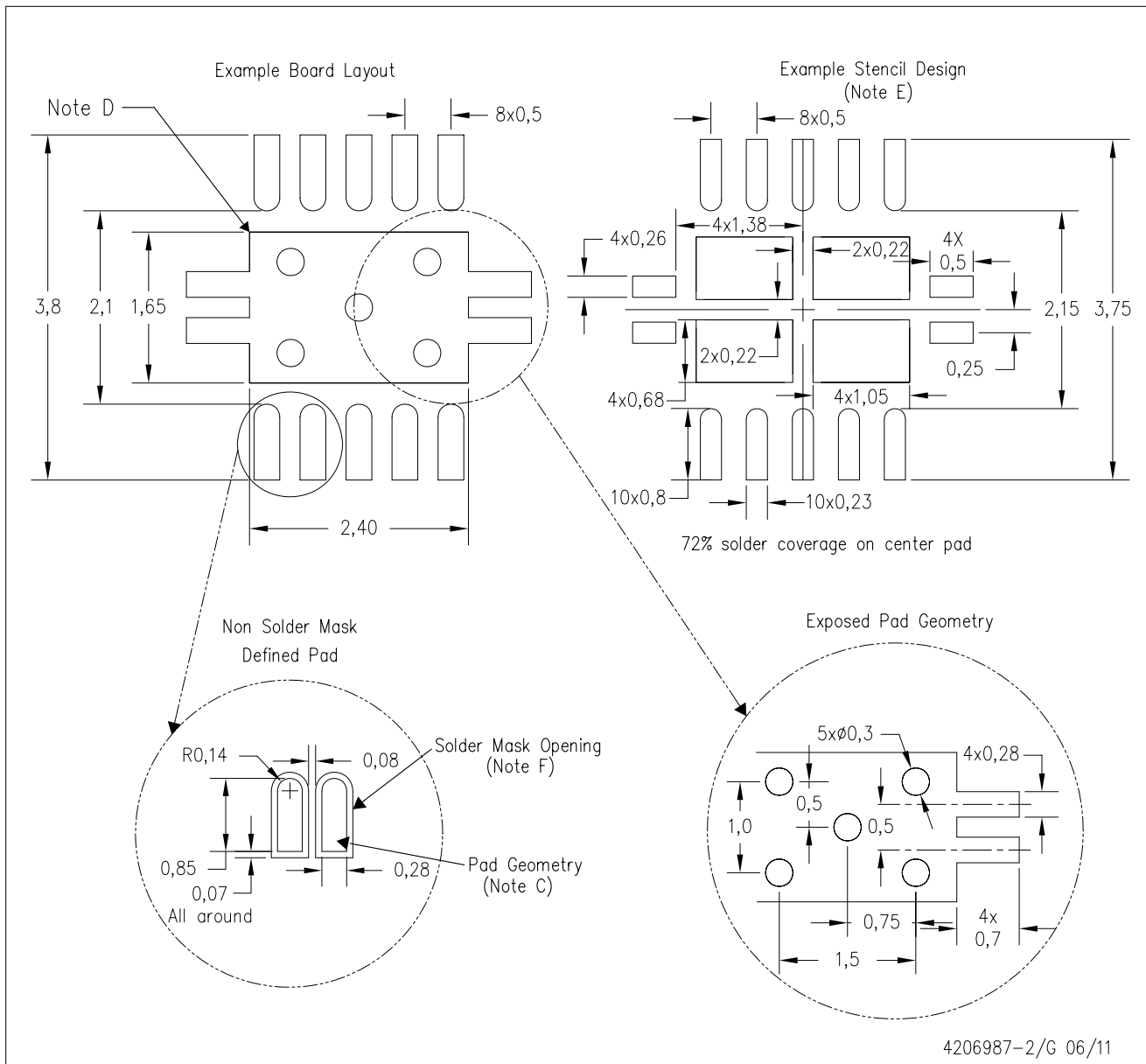

- NOTES:
- A. All linear dimensions are in millimeters.
  - B. This drawing is subject to change without notice.
  - C. Publication IPC-7351 is recommended for alternate designs.
  - D. This package is designed to be soldered to a thermal pad on the board. Refer to Application Note, Quad Flat-Pack Packages, Texas Instruments Literature No. SLUA271, and also the Product Data Sheets for specific thermal information, via requirements, and recommended board layout. These documents are available at [www.ti.com](http://www.ti.com) <<http://www.ti.com>>.
  - E. Laser cutting apertures with trapezoidal walls and also rounding corners will offer better paste release. Customers should contact their board assembly site for stencil design recommendations. Refer to IPC 7525 for stencil design considerations.
  - F. Customers should contact their board fabrication site for minimum solder mask web tolerances between signal pads.

DSC (S-PWSON-N10)

PLASTIC SMALL OUTLINE NO-LEAD

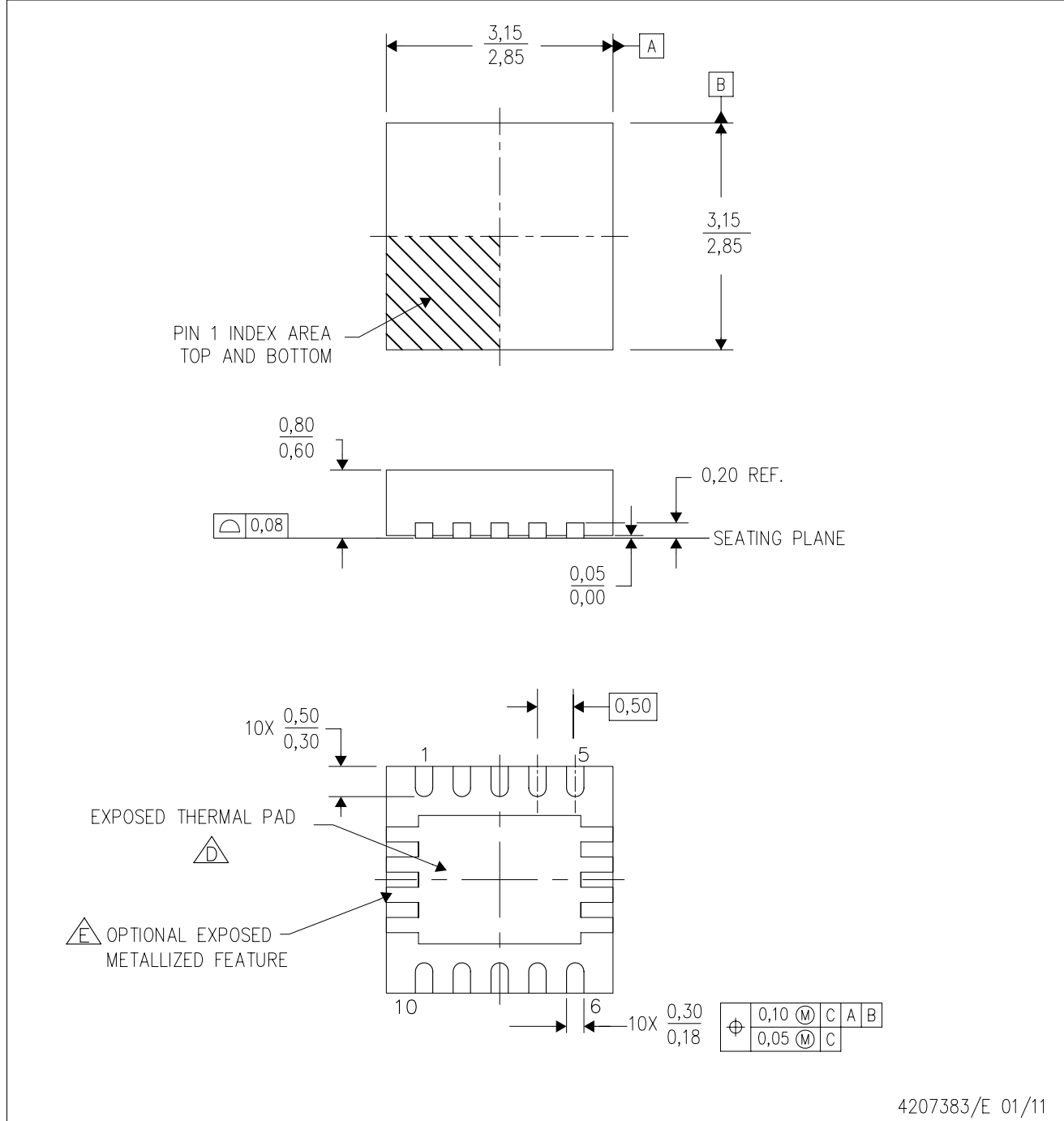

- NOTES:
- A. All linear dimensions are in millimeters. Dimensioning and tolerancing per ASME Y14.5M-1994.
  - B. This drawing is subject to change without notice.
  - C. Small Outline No-Lead (SON) package configuration.
  - The package thermal pad must be soldered to the board for thermal and mechanical performance.
  - See the Product Data Sheet for details regarding the exposed thermal pad features and dimensions.

# THERMAL PAD MECHANICAL DATA

DSC (S-PWSON-N10)

PLASTIC SMALL OUTLINE NO-LEAD

## THERMAL INFORMATION

This package incorporates an exposed thermal pad that is designed to be attached directly to an external heatsink. The thermal pad must be soldered directly to the printed circuit board (PCB). After soldering, the PCB can be used as a heatsink. In addition, through the use of thermal vias, the thermal pad can be attached directly to the appropriate copper plane shown in the electrical schematic for the device, or alternatively, can be attached to a special heatsink structure designed into the PCB. This design optimizes the heat transfer from the integrated circuit (IC).

For information on the Quad Flatpack No-Lead (QFN) package and its advantages, refer to Application Report, QFN/SON PCB Attachment, Texas Instruments Literature No. SLUA271. This document is available at [www.ti.com](http://www.ti.com).

The exposed thermal pad dimensions for this package are shown in the following illustration.

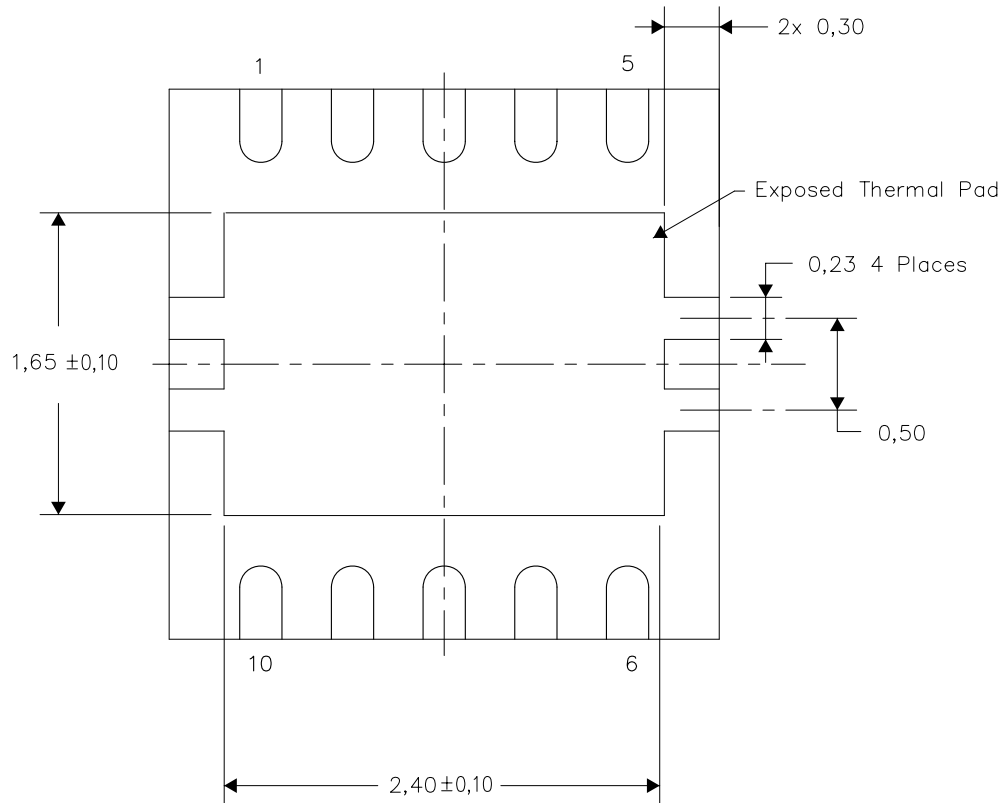

Bottom View

Exposed Thermal Pad Dimensions

4210391-2/F 04/11

NOTE: A. All linear dimensions are in millimeters



## IMPORTANT NOTICE

Texas Instruments Incorporated and its subsidiaries (TI) reserve the right to make corrections, modifications, enhancements, improvements, and other changes to its products and services at any time and to discontinue any product or service without notice. Customers should obtain the latest relevant information before placing orders and should verify that such information is current and complete. All products are sold subject to TI's terms and conditions of sale supplied at the time of order acknowledgment.

TI warrants performance of its hardware products to the specifications applicable at the time of sale in accordance with TI's standard warranty. Testing and other quality control techniques are used to the extent TI deems necessary to support this warranty. Except where mandated by government requirements, testing of all parameters of each product is not necessarily performed.

TI assumes no liability for applications assistance or customer product design. Customers are responsible for their products and applications using TI components. To minimize the risks associated with customer products and applications, customers should provide adequate design and operating safeguards.

TI does not warrant or represent that any license, either express or implied, is granted under any TI patent right, copyright, mask work right, or other TI intellectual property right relating to any combination, machine, or process in which TI products or services are used. Information published by TI regarding third-party products or services does not constitute a license from TI to use such products or services or a warranty or endorsement thereof. Use of such information may require a license from a third party under the patents or other intellectual property of the third party, or a license from TI under the patents or other intellectual property of TI.

Reproduction of TI information in TI data books or data sheets is permissible only if reproduction is without alteration and is accompanied by all associated warranties, conditions, limitations, and notices. Reproduction of this information with alteration is an unfair and deceptive business practice. TI is not responsible or liable for such altered documentation. Information of third parties may be subject to additional restrictions.

Resale of TI products or services with statements different from or beyond the parameters stated by TI for that product or service voids all express and any implied warranties for the associated TI product or service and is an unfair and deceptive business practice. TI is not responsible or liable for any such statements.

TI products are not authorized for use in safety-critical applications (such as life support) where a failure of the TI product would reasonably be expected to cause severe personal injury or death, unless officers of the parties have executed an agreement specifically governing such use. Buyers represent that they have all necessary expertise in the safety and regulatory ramifications of their applications, and acknowledge and agree that they are solely responsible for all legal, regulatory and safety-related requirements concerning their products and any use of TI products in such safety-critical applications, notwithstanding any applications-related information or support that may be provided by TI. Further, Buyers must fully indemnify TI and its representatives against any damages arising out of the use of TI products in such safety-critical applications.

TI products are neither designed nor intended for use in military/aerospace applications or environments unless the TI products are specifically designated by TI as military-grade or "enhanced plastic." Only products designated by TI as military-grade meet military specifications. Buyers acknowledge and agree that any such use of TI products which TI has not designated as military-grade is solely at the Buyer's risk, and that they are solely responsible for compliance with all legal and regulatory requirements in connection with such use.

TI products are neither designed nor intended for use in automotive applications or environments unless the specific TI products are designated by TI as compliant with ISO/TS 16949 requirements. Buyers acknowledge and agree that, if they use any non-designated products in automotive applications, TI will not be responsible for any failure to meet such requirements.

Following are URLs where you can obtain information on other Texas Instruments products and application solutions:

### Products

Audio	<a href="http://www.ti.com/audio">www.ti.com/audio</a>
Amplifiers	<a href="http://amplifier.ti.com">amplifier.ti.com</a>
Data Converters	<a href="http://dataconverter.ti.com">dataconverter.ti.com</a>
DLP® Products	<a href="http://www.dlp.com">www.dlp.com</a>
DSP	<a href="http://dsp.ti.com">dsp.ti.com</a>
Clocks and Timers	<a href="http://www.ti.com/clocks">www.ti.com/clocks</a>
Interface	<a href="http://interface.ti.com">interface.ti.com</a>
Logic	<a href="http://logic.ti.com">logic.ti.com</a>
Power Mgmt	<a href="http://power.ti.com">power.ti.com</a>
Microcontrollers	<a href="http://microcontroller.ti.com">microcontroller.ti.com</a>
RFID	<a href="http://www.ti-rfid.com">www.ti-rfid.com</a>
RF/IF and ZigBee® Solutions	<a href="http://www.ti.com/lprf">www.ti.com/lprf</a>

### Applications

Communications and Telecom	<a href="http://www.ti.com/communications">www.ti.com/communications</a>
Computers and Peripherals	<a href="http://www.ti.com/computers">www.ti.com/computers</a>
Consumer Electronics	<a href="http://www.ti.com/consumer-apps">www.ti.com/consumer-apps</a>
Energy and Lighting	<a href="http://www.ti.com/energy">www.ti.com/energy</a>
Industrial	<a href="http://www.ti.com/industrial">www.ti.com/industrial</a>
Medical	<a href="http://www.ti.com/medical">www.ti.com/medical</a>
Security	<a href="http://www.ti.com/security">www.ti.com/security</a>
Space, Avionics and Defense	<a href="http://www.ti.com/space-avionics-defense">www.ti.com/space-avionics-defense</a>
Transportation and Automotive	<a href="http://www.ti.com/automotive">www.ti.com/automotive</a>
Video and Imaging	<a href="http://www.ti.com/video">www.ti.com/video</a>
Wireless	<a href="http://www.ti.com/wireless-apps">www.ti.com/wireless-apps</a>

TI E2E Community Home Page

[e2e.ti.com](http://e2e.ti.com)

Mailing Address: Texas Instruments, Post Office Box 655303, Dallas, Texas 75265  
Copyright © 2011, Texas Instruments Incorporated